

MEGATEX®

ÇUVAL AĞZI DİKİŞ MAKİNALARI BAG CLOSING MACHINES

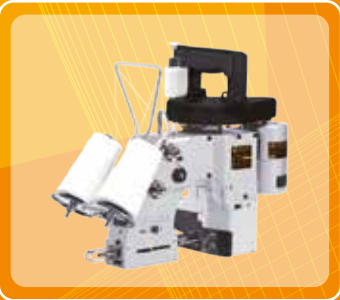

Portatif Çuval Ağzı Kapatıcı

- Maks. dikiş hızı 1800-200 devir
- İstenilen hızda ayarlanabilir (opsiyonel)
- Güvenlik için özel malzeme yapımı plastik kol
- Güçlü yağlayıcı
- Kağıt, pamuk, pp/pe, kendir, çuval bezi vs. gibi tüm çeşitlerdeki çuvalların ağzını kapatmak için
- Otomatik iplik kesici
- Düşük Ses
- En az bakım

Fermeture de sac portatif

- Vitesse de couture max, 1800~2000s.p.m.
- Plus efficace pour le machinisme amélioré.
- Matériaux spéciaux pour la poignée plastique de securite.
- Graisseur supérieur puissant
- Pour fermer toutes sortes de papiers, cotons, pp / pe, et toiles de jute...etc,
- Coupe-fil automatique
- Bruit bas
- Entretien minimum

Maquina portatil para cerrar sacos

- Velocidad máxima de coser 1800~2000 vuelta por minuto
- Más efectivo por mecanismo avanzado
- Materiales especiales para manilla plástica de seguridad
- Lubricador de potencia superior
- Para cierre de todo tipo de papel, algodón, pp / pe, yute,etc.
- Ribeteador de hilo automático
- Ruido mínimo
- Mantenimiento mínimo

Portable Bag Closer

- Max sewing speed 1800-200 s.p.m
- More effective for technical revolution
- Special material for safety plastic handle
- Superior powerful lubricator
- For bag closing all kinds of paper,cotton,pp/pe, hessian, Jute etc.
- Automatic thread trimmer
- Lower noise
- Minimum maintenance

Nähmaschine fur tragbare säcke

- Max, nähgeschwindigkeit 1800~2000s.p.m.
- Mehr effektiv durch den verbesserten mechañismus
- Spezielles material fur den sicherheitsgriff aus plastik
- Hervorragende nochdruckschmierung
- Damit alle sorten von papier, baumwolle, pp / pe, sackleinwand, jute usw, zugemacht werden können.
- Automatischer fadentrimmer
- Gerauscharm
- Leichte wartung

Balanser Seçenekleri

- **SB-1,5K** 1.5 kg uygun fiyatlı / affordable
- **SB-9K** 9.0 kg uygun fiyatlı / affordable
- **SB-3K** 3.0 kg uygun fiyatlı / affordable
- **SB-15K** 15 kg uygun fiyatlı / affordable
- **SB-5K** 5.0 kg uygun fiyatlı / affordable
- **SB-7 K** 7.0 kg uygun fiyatlı / affordable

SB-100
Asma Kancası
Hanging hook



● Özellikler / Specifications

● Otomatik iplik kesici / Automatic thread

Model Model	İplik Thread	Hız Speed	Dikiş Stitch	İğne Needle	Kesici Cutter	Net Ağırlık N.W.	Brüt Ağırlık G.W.
F300A	1	300~400	7.2mm	FD-5	●	6,1 kg	7,7 kg
F302A	2	çuval/saat	7.2mm	#24,25	●	7,0 kg	8,2 kg
MF300A	1	300~400	7.2mm	FD-5	●	30 kg	34 kg
MF302A	2	çuval/saat	7.2mm	#24,25	●	30 kg	34 kg
N600A	1	250~350	7.2mm	DN X 1	●	6,1 kg	7,7 kg
N602A	2	çuval/saat	7.2mm	#25	●	7,0 kg	7,2 kg
N600H	1	350~450	7.2mm	DN X 1	●	6,1 kg	7,7 kg
N602H	2	çuval/saat	7.2mm	#25	●	7,0 kg	7,2 kg
N600AC	1	250~350	7.2mm	DN X 1	manuel tap cutter	8,0 kg	9,0 kg
N602AC	2	çuval/saat	7.2mm	#25	manuel tap cutter	8,0 kg	9,0 kg
N620A	2	250~350 350~450	7.2mm	DN X 1	●	7,0 kg	8,5 kg
N620H	2	çuval/saat	7.2mm	#25	●	7,0 kg	8,5 kg
FN600A	1	200~300	7.2mm	DN X 1	●	50,0 kg	54,0 kg
FN602A	2	çuval/saat	7.2mm	#25	●	50,0 kg	54,0 kg
MN600A	1	200~300	7.2mm	DN X 1	●	30 kg	34 kg
MN602A	2	çuval/saat	7.2mm	#25	●	30 kg	34 kg
N320A	2	160~230 çuval/saat	7.2mm	DN X 1 #25	●	7,0 kg	8,5 kg

- Yağ pompası yağlama sistemi, yağ hattını ana hareketli parçalara yönlendirir

- Oil pump lubrication system, oil line directs lubricant to main moving parts.

- Systeme lubrifiant de pompe de l'huile, le graissage direct des conduites de l'huile pour faire fonctionner bien les pieces.

- Oldruck-Schmiersystem, das schmieröl wird direkt in die antriebs-teile geleitet.

- Sistema de lubricación con bomba de aceite, por lubricanete por lineas directas a las piezas.

Motor sadece 12V ve 220V seçeneği olarak temin edilir.

N600A

1- iplik / thread

N600H

1- iplik / thread
Yüksek hız
High speed



N620A

2- iplik / thread

N620H

2- iğne/needle
2- iplik/thread
Yüksek hız / High speed



N602A

2- iplik / thread

N602H

2- iplik / thread
Yüksek hız
High speed



N320A

2- iplik / thread

Ağır şartlar için çuval ağzı dikiş makinesi
Bag Closer for Heavy Use



N600AC

1- iplik / thread

Krep Kağıt Aparatlı Makine
Equipped Taping Attachment

N602AC

2- iplik / thread



Mevcut bant boyutları:
Tape sizes available:
50 mm, 70 mm

Özellikleri

- Bu model makina kraft torbaların ağzına krep kağıt dikmek için tasarlanmış özel krep aparatı ile çalışır.
- Kraft torbaların içindeki ürünün dökülmemesi için kesin çözüm.
- Bu model çuval kenarındaki bantlar ve ipler için bir kesici içerir
- Standart dikiş düzeni için çıkarılabilir

Features

- This model are equipped closing taping attachment allow users to bind bag tops with crepped paper tape.
- Tape binding reduces sifting of finely divided products and adds a finished appearance to sewn bags.
- This model Includes a cutter to Serve tape and thread at bag edge.
- Removable for convention to standard sewing.

F300A

1- iplik / thread



F302A

2- iplik / thread



MN600A

1- iplik
thread

MN602A

2- iplik
thread



MF300A

1- iplik
thread

MF302A

2- iplik
thread



Moved closing machine
Taşınabilir kapatma makinesi

Özellikleri

- Bu makineyi gereken bir yere taşımak çok kolay ve rahattır.
- Bir opsiyonel ayak pedalı ve acil durum şalteri mevcuttur.
- Üretimleri daha fazla artırabilir

Features

- This machine is very easy to handle and convenient to move to a place you need
- An optional foot switch is available to control head start and stop functions.
- Can increase more production .

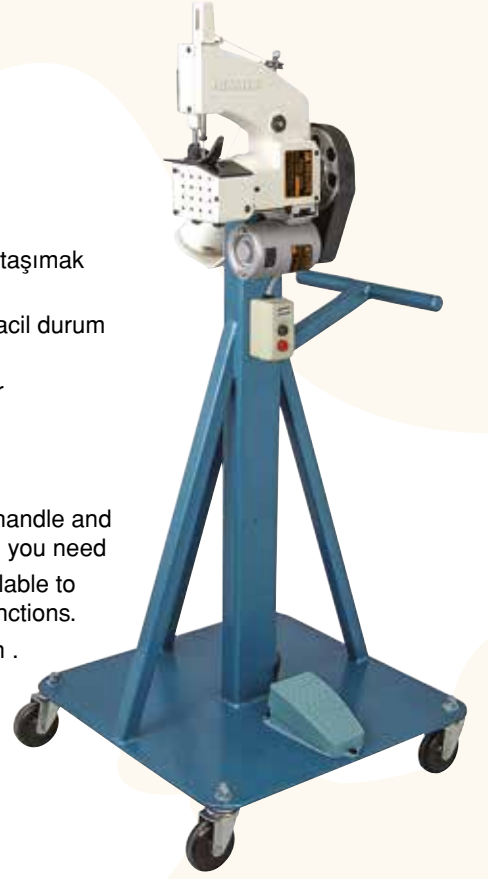

FN600A

1- iplik
thread

FN602A

2- iplik
thread

Kızaklı - Kraft Torba Makinası
Sliding board closing machine

Özellikleri

- Model N600A sabit istasyon kullanımı için manuel olarak ayarlanabilen yükseklik ayarlı ve manuel konveyör bileşimleri sunar.
- Manuel konveyör
- İstenirse fotosel ile otomatik çalışma imkanı
- Dikiş kafasını başlatma ve durdurma fonksiyonlarını kontrol etmek için bir ayak pedalı ile çalışır.



Features

- Offers manually adjustable pedestal and carriage conveyor combinations for fixed station use of model N600A
- Flat moving carriage is fitted with grooved wheels for easy motion of the bag past the sewing heads'.
- Track is constructed of heavy-grooved angle iron with rigid cross-braks the pedestal height is offered 85 cm.
- Rubber stops at either end of the track sections limit carriage Travel, track length of 120 cm
- An option foot switch is to control sewing head start and stop functions.

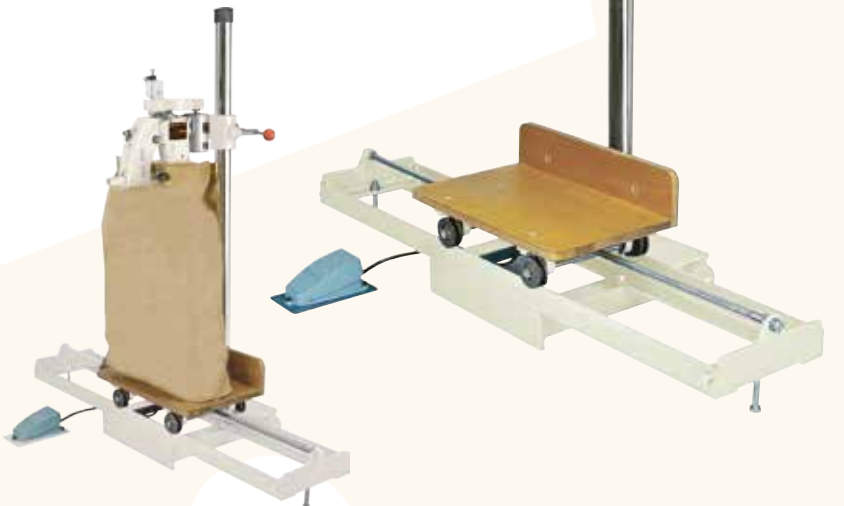

F900A

1-İğne -2- ipli zincir dikiş.
1-Needle 2- thread chain stitch



F900AC

1-İğne -2- ipli zincir dikiş.
1-Needle 2- thread chain stitch



Prömatik kesme iplik ve krep bant
Pneumatic cutting thread and tape.



F900AT

1-İğne -2- ipli zincir dikiş.
1-Needle 2- thread chain stitch

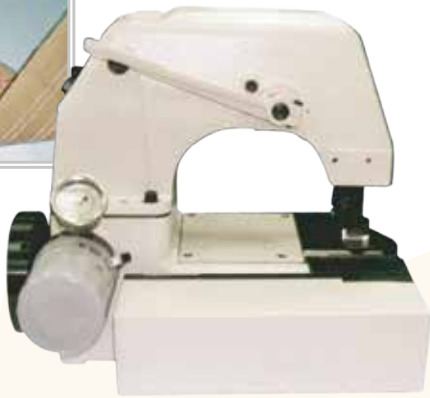

Otomatik - Prömatik döner bıçak
Pneumatic rotary knife

F920A

2-İğne -4- ipli zincir dikiş.
2-Needle 4- thread chain stitch



Otomatik - Prömatik döner bıçak
Pneumatic rotary knife



Model Model	Speed Hız	Material thickness (Max.) (mm)	Dikiş Stitch	Dikiş tipi Stitch type	Kapatma tipi Closure type	Kesici tipi Cutter type	Bant kesici Tape cutter	Hava basıncı) Air pressure (kg/cm ²)	Hava tüketimi Air consumption	Net ağırlık N.W	Brüt ağırlık G.W.
F900A	80 fit / feed (2438 cm) per min / beher dak	8	7~17	1-İğne 2-iplik 1-needle 2-thread	Standart dikiş Standard sew	Giyotin stili Guillotine style	Yok Non	----	----	29 kg	30 kg
F900AC	80 fit / feed (2438 cm) per min / beher dak	8	7~17	1-İğne 2-iplik 1-needle 2-thread	Standart dikiş Standard sew	Auto scis- sors style Otomatik makas stili	Auto scis- sors style Otomatik makas stili	4	3.5	32 kg	33 kg
F900AT	80 fit / feed (2438 cm) per min / beher dak	8	7~17	1-İğne 2-iplik 1-needle 2-thread	Standart dikiş Standard sew	Prömatik döner bıçak stili Pneumatic rotary kniff style	Yok Non	4	4	32 kg	33 kg
F920A	80 fit / feed (2438 cm) per min / beher dak	8	7~17	2-İğne 4-iplik 2-needle 4-thread	Standart dikiş Standard sew	Giyotin stili Guillotine style	Yok Non	----	----	29 kg	30 kg

YÜKSEK HIZLI 1-İĞNE OTOMATİK-YAĞLAMA SİSTEMLİ 2-İPLİ ZİNCİR DİKİŞLİ ÇUVAL AĞZI DİKİŞ MAKİNALARI HIGH SPEED 1-NEEDLE 2-THREAD CHAIN STITCH BAG CLOSING HEADS WITH AUTO-LUBRICATION SYSTEM

N980A

1 iğne - 2 iplik
1 needle
2 thread

N980AW

2 iğne - 4 iplik
2 needle
4 thread

Düz dikiş için manuel
For plain sew.



N980AC

1 iğne - 2 iplik
1 needle
2 thread

N980ACW

2 iğne - 4 iplik
2 needle
4 thread

Düz dikiş için otomatik
For crepe of plain sew.



1. Havalı giyotin tipi krep kağıt ataçmanı kesici ile donanımlıdır.
2. Krep bant opsiyoneldir.

1. Equipped with pneumatic quillotine type crepetape cutter
2. Crepe tape binder is optional.



Model Model	Speed Hız r.p.m	Material thickness (Max.) (mm)	Dikiş Stitch	Dikiş tipi Stitch type	Kesici tipi Cutter type	Kapatma tipi Closing type	Hava basıncı) Air pressure (kg/cm ²)	Hava tüketimi Air consumption	Net ağırlık N.W	Brüt ağırlık G.W.
N980A	2700	8	7~11,5	1-iğne 2-iplik 1-needle 2-thread	machinacal thread cutter	Plain only	----	----	45 kg	47 kg
N980AW	2500	8	7~11,5	2-iğne 4-iplik 2-needle 4-thread	machinacal thread cutter	Plain only	----	----	45 kg	47 kg
N980AC	2700	8	7~10,5	1-iğne 2-iplik 1-needle 2-thread	pneumatic thread / Tape Cutter	Plain only Plain /Tape Bound closing	4	3,5	45 kg	47 kg
N980ACW	2500	8	7~10,5	2-iğne 4-iplik 2-needle 4-thread	pneumatic thread / Tape Cutter	Plain only Plain /Tape Bound closing	4	3,5	45 kg	47 kg
N980AP	2700	8	7~10,5	1-iğne 1-iplik 1-needle 1-thread	machinacal thread cutter	Plain only	----	----	45 kg	47 kg
N980ACP	2700	8	7~10,5	1-iğne 1-iplik 1-needle 1-thread	pneumatic thread / Tape Cutter	Plain only Plain /Tape Bound closing	----	----	45 kg	47 kg

FACC-N980AC

Fotoselli başlatma, durdurma ve kesme, pnömatik kesme iplik ve krepe bant.

Photo - electric start, stop and cutting, pneumatic cutting thread and crepe tape.

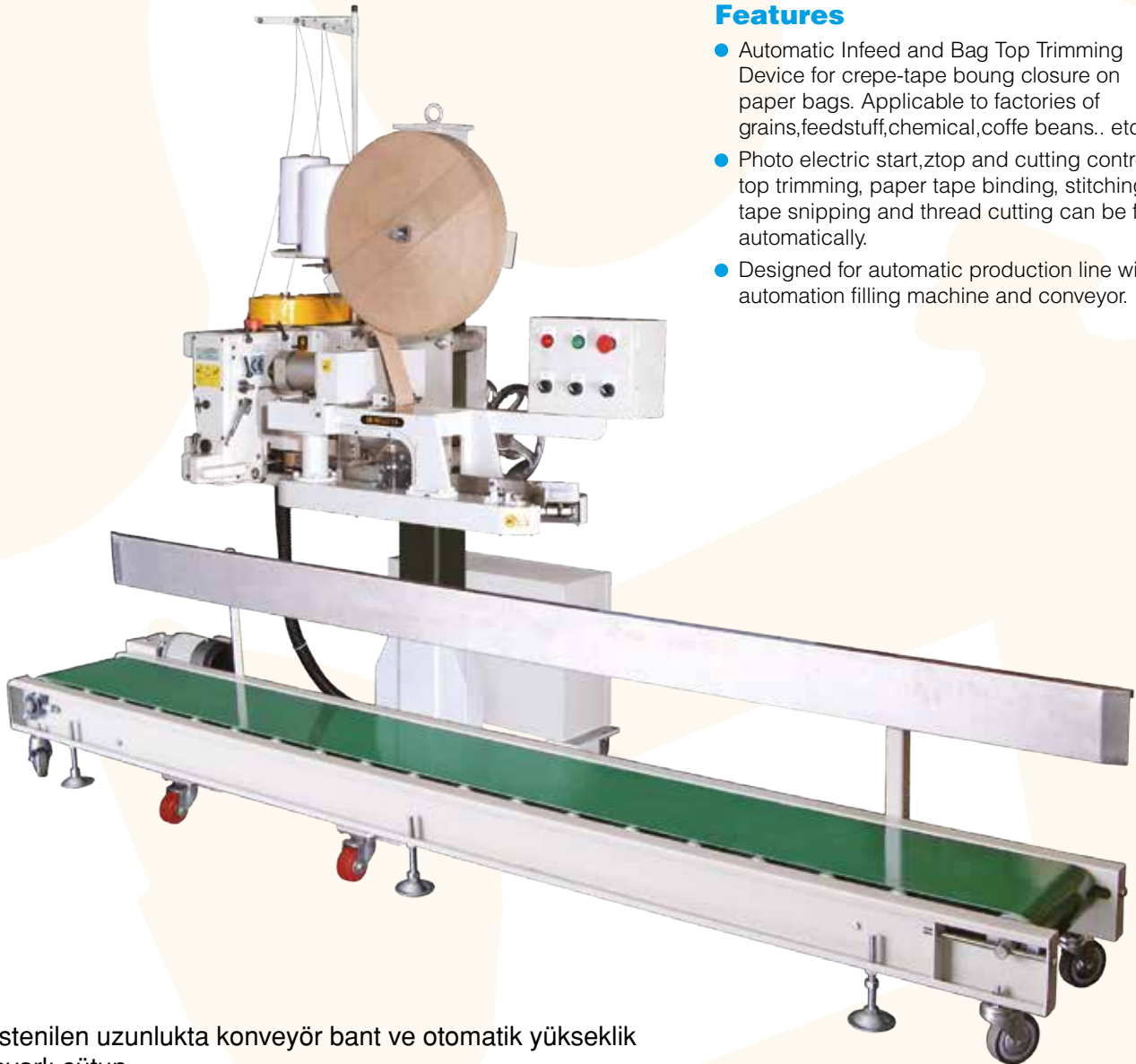

İstenilen uzunlukta konveyör bant ve otomatik yükseklik ayarlı sütun.

Özellikleri

- Otomatik Besleme ve Çuval Üstü Düzeltme Cihazı, kağıt çuvallarda krepe-bant takarak kapatma içindir. Tohum, gıda maddesi, kimyasal, kahve çekirdeği vb. fabrikalarda kullanılabilir.
- Fotoselli başlatma, durdurma ve kesme kontrolleri. Çuval üstü kırma, kağıt bant takma, dikiş kağıt bantı kesme ve iplik kesme otomatik olarak tamamlanabilir.
- Otomatik dolum makinesi ve konveyör ile otomatik üretim hattı için tasarlanmıştır.

Features

- Automatic Infeed and Bag Top Trimming Device for crepe-tape bounng closure on paper bags. Applicable to factories of grains, feedstuff, chemical, coffe beans. etc.
- Photo electric start, ztop and cutting controls. Bag top trimming, paper tape binding, stitching paper tape snipping and thread cutting can be finished automatically.
- Designed for automatic production line with automation filling machine and conveyor.

Model Model	Speed Hız r.p.m	İğne Needle	Dikiş Stitch	Material thickness (Max.) (mm)	Dikiş sistemi Stitch System	Motor	Height adjustment range	Work Plate size
FACC-N980AC	500-600 bags/hour	DRX2 #26	7~11 mm	8 mm	Çift zincir dikiş Double chainstitch	3Hp/220V 1/2Hp	720~1200 mm	450 x 300 mm

MEGATEX®



Uygun Fiyatlı , Orjinal  Megatex Yedek Parçalar

MEGATEX®



Uygun Fiyatlı ,  Megatex Yedek Parçalar